

# WESTEN

# quasar D

IT

**caldaia murale a gas ad alto rendimento**

manuale per l'uso destinato all'utente ed all'installatore

EN

**High performance gas-fired wall-mounted boilers**

Operating and installation instructions

ES

**Caldera mural de gas de alto rendimiento**

Manual para el usuario y el instalador

RU

**Высокопроизводительные настенные газовые котлы**

Руководство по установке и эксплуатации

HU

**Magas hozamú fali gázkazán**

Felhasználói és szerelési kézikönyv

RO

**Centrale murale pe gaz cu randament ridicat**

Instrucțiuni pentru instalator și pentru utilizator

EL

GR

**Επιτοίχιος λέβητας αερίου υψηλής αποδοσης**

ΕΓΧΕΙΡΙΔΙΟ ΧΡΗΣΗΣ ΓΙΑ ΤΟ ΧΡΗΣΤΗ ΚΑΙ ΤΟΝ ΕΓΚΑΤΑΣΤΑΤΗ

CE 0051



MP02

Dear Customer,

We are confident your new boiler will meet all your requirements.

All **WESTEN** products have been designed to give you what you are looking for: good performance combined with simple and rational use.

Please do not put away this booklet without reading it first as it contains some useful information which will help you to operate your boiler correctly and efficiently.

Do not leave any packaging (plastic bags, polystyrene, etc.) within the reach of children as they are a potential source of danger.

**WESTEN** declares that these models of boiler bear the CE mark in compliance with the basic requirements of the following Directives:

- Gas Directive 2009/142/EC
- Efficiency Directive 92/42/EEC
- Electromagnetic Compatibility Directive 2004/108/EC
- Low Voltage Directive 2006/95/EC



## CONTENTS

### INSTRUCTIONS FOR USERS

1. Instructions prior to installation	28
2. Instructions prior to commissioning	28
3. Commissioning the boiler	29
4. Adjusting ambient temperature and DHW temperature	29
5. Description of button  (Summer - Winter - Heating only - Off)	30
6. Filling the system	30
7. Turning off the boiler	30
8. Gas conversion	31
9. Prolonged shutdown. Frost protection (central heating circuit)	31
10. Troubleshooting	31
11. Routine maintenance instructions	31

### INSTRUCTIONS FOR FITTERS

12. General information	32
13. Instructions prior to installation	32
14. Installing the boiler	33
15. Dimensions of boiler	33
16. Installation of flue and air ducts	34
17. Connecting the mains supply	38
18. Connecting the ambient thermostat	38
19. Gas conversion methods	39
20. Visualisation of electronic board parameters on boiler display ("info" function)	41
21. Parameters setting	42
22. Adjustment and safety devices	43
23. Positioning the ignition and flame-sensor electrode	44
24. Checking combustion parameters	44
25. Output/pump head performance	44
26. Connecting the external probe	45
27. Notes for installations with separate outlets	45
28. Annual servicing	46
29. Circuit diagram	47-48
30. Illustrated wiring diagram	49-50
31. Technical data	51

# 1. INSTRUCTIONS PRIOR TO INSTALLATION

This boiler has been designed to heat water to a temperature lower than boiling point at atmospheric pressure. It must be connected to a central heating system and to a domestic hot water supply system according to its performance and power output.

Before having the boiler installed by a qualified service engineer, make sure the following operations are performed:

- a) Make sure that the boiler is adjusted to use the type of gas delivered by the gas supply. To do this, check the markings on the packaging and the rating plate on the appliance.
- b) Make sure that the flue terminal draft is appropriate, that the terminal is not obstructed and that no exhaust gases from other appliances are expelled through the same flue duct, unless the latter has been specially designed to collect exhaust gas from more than one appliance, in compliance with current laws and regulations.
- c) Make sure that, if the boiler is connected to existing flue ducts, these have been thoroughly cleaned as residual products of combustion may detach from the walls during operation and obstruct the flow of fumes.
- d) To ensure correct operation and maintain the warranty, observe the following precautions:

## 1. DHW circuit:

- 1.1. If the water is harder than 20 °F (1 °F = 10 mg calcium carbonate per litre of water), install a polyphosphate dispenser or an equivalent treatment system, compliant with current regulations.
- 1.2. Thoroughly flush the system after installation of the appliance and before use.
- 1.3. The materials used for the domestic hot water circuit of the product comply with Directive 98/83/EC.

## 2. Heating circuit

### 2.1. new system

Before proceeding with installation of the boiler, the system must be cleaned and flushed to eliminate residual thread-cutting swarf, solder and any solvents, using suitable proprietary products. To avoid damaging metal, plastic and rubber parts, only use neutral cleaners, i.e. non-acid and non-alkaline. Recommended cleaning products are: SENTINEL X300 or X400 and FERNOX Regenerator for heating circuits. Use these products in strict compliance with the manufacturers' instructions.

### 2.2. existing plant:

Before installing the boiler, drain the system and clean it to remove sludge and contaminants, using suitable proprietary products as described in section 2.1. To avoid damaging metal, plastic and rubber parts, use only neutral cleaners, i.e. non-acid and non-alkaline such as SENTINEL X100 and FERNOX Protector for heating circuits. Use these products in strict compliance with the manufacturers' instructions. Remember that the presence of foreign bodies in the heating system can adversely affect boiler operation (e.g. overheating and excessive noise of the heat exchanger).

---

**Failure to observe the above will render the guarantee null and void.**

---

# 2. INSTRUCTIONS PRIOR TO COMMISSIONING

Initial lighting of the boiler must be carried out by an authorised Service Engineer who must first ensure that:

- a) the rated data correspond to the supply (electricity, water and gas) data;
  - b) the installation complies with current laws and regulations;
  - c) the appliance is correctly connected to the power supply and earthed.
- The names of the authorised Service Centres are indicated in the attached sheet.

Failure to observe the above will render the guarantee null and void.

Prior to commissioning, remove the protective plastic coating from the boiler. Do not use any tools or abrasive detergents to do this as you may damage the painted surfaces.

---

***The instructions shall state the substance of the following:***

***This appliance is not intended for use by persons (including children) with reduced physical, sensory or mental capabilities, or lack of experience and knowledge, unless they have been given supervision or instruction concerning use of the appliance by a person responsible for their safety.***

***Children should be supervised to ensure that they do not play with the appliance.***

---

### 3. COMMISSIONING THE BOILER

To light the boiler correctly, proceed as follows:

- 1) power the boiler
- 2) open the gas tap;
- 3) press the button (⏻) and switch the boiler to Summer (☀️), Winter (❄️) or heating only (🔥);
- 4) press the heating circuit (🔥) and domestic hot water circuit (🚿) temperature adjustment buttons (+/-) in order to ignite the main burner.

When the boiler is lit, the symbol (🔥) will appear on the display.

In the Summer position (☀️) the main burner will only ignite if a DHW tap is turned on.

#### Warning:

During initial ignition, the burner may not ignite (causing the boiler to shut down) until any air in the gas pipes is vented. In this case, repeat the ignition procedure until gas reaches the burner. Press button (R), for at least 2 seconds.

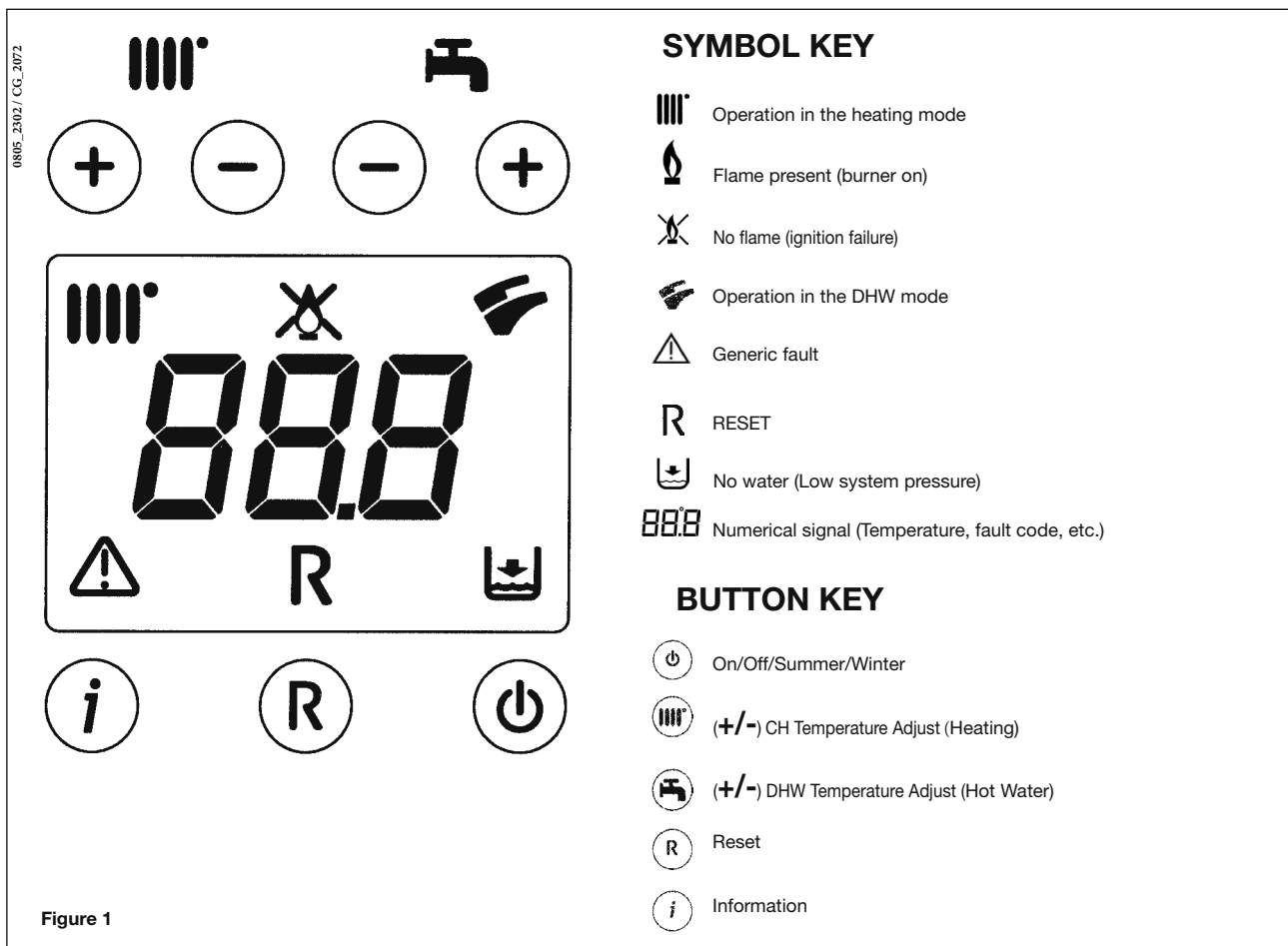

### 4. ADJUSTING AMBIENT TEMPERATURE AND DHW TEMPERATURE

The system must be equipped with an ambient thermostat for controlling the room temperature.

Adjust the ambient temperature (🔥) and the DHW temperature (🚿) by pressing the respective +/- buttons (figure 1).

The ignition of the burner is shown on the display with the symbol (🔥) as described in section 3.1.

#### HEATING

While the boiler is operating in heating mode, the display (figure 1) shows the flashing symbol (🔥) and the heating delivery temperature (°C).

#### DOMESTIC HOT WATER



While the boiler is operating in DHW mode, the display (figure 1) shows the flashing symbol (🚿) and the DHW output temperature (°C).

## 5. DESCRIPTION OF BUTTON (Summer - Winter - Heating Only - Off)



Press this button to set the following boiler operating modes:

- SUMMER
- WINTER
- HEATING ONLY
- OFF

In **SUMMER** mode, the display shows . The boiler satisfies requests for DHW only while central heating is NOT enabled (ambient frost protection function active).

In **WINTER** mode, the display shows  and . The boiler satisfies requests for both DHW and central heating (ambient frost protection function active).

In **HEATING ONLY** mode, the display shows . The boiler satisfies requests for central heating only (ambient frost protection function active).

In **OFF** mode, the display shows neither of the above two symbols ( ). In this mode only the ambient frost protection function is enabled, any other request for DHW or heating is not satisfied.

## 6. FILLING THE SYSTEM

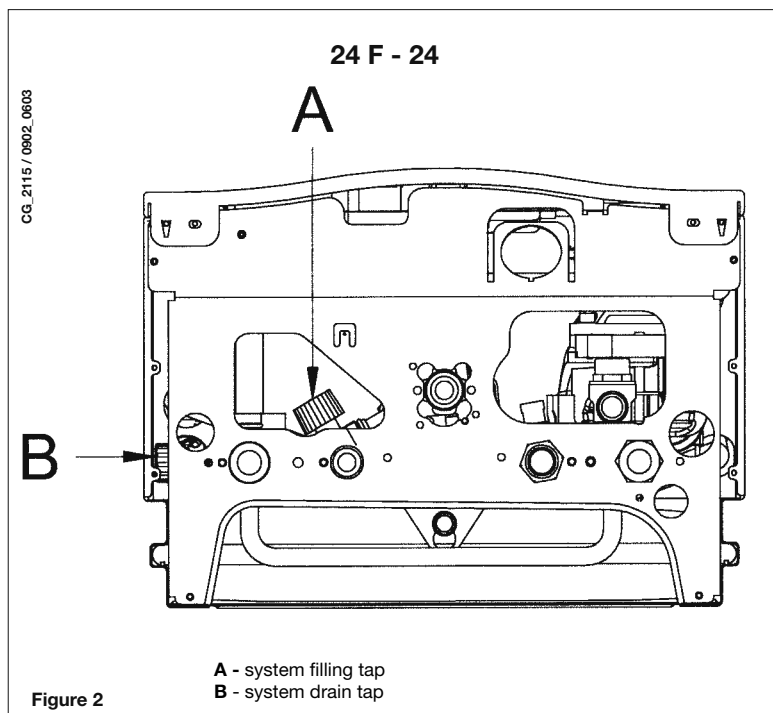

### WARNING

Disconnect the boiler from the mains power supply using the two-pole switch.

**IMPORTANT:** Regularly check that the pressure displayed on the pressure gauge is 0.7 - 1.5 bar, with the boiler cold. In case of overpressure, open the boiler drain tap. In case of insufficient temperature, open the boiler filling tap (figure 3). Open the tap very slowly in order to vent the air.

The boiler is fitted with a hydraulic pressure gauge which prevents the boiler from working if there is no water.

**N.B.:** In case pressure drops occur frequently, have the boiler checked by an authorised Service Engineer.

## 7. TURNING OFF THE BOILER

To switch off the boiler, disconnect the electric power supply.

In OFF mode (section 5) the boiler remains off (the display indicates OFF) but the electrical circuits remain live and the frost protection device is enabled (section 9).

## 8. GAS CONVERSION

The boilers can operate both on natural gas and **LPG**.  
All gas conversions must be made by an authorised Service Engineer.

## 9. PROLONGED SHUTDOWN. FROST PROTECTION

Do not drain the whole system as filling up with water again causes unnecessary and harmful scale to build up inside the boiler and the heating elements. If the boiler is not used during winter and is therefore exposed to the danger of frost, add some specific anti-freeze to the water in the system (e.g.: propylene glycol coupled with corrosion and scale inhibitors). The electronic boiler management system includes a "frost protection" function for the heating system which, when delivery temperature falls below 5°C, operates the burner until a delivery temperature of 30°C is reached.

The frost protection function is enabled if:

- \* the boiler is electrically powered;
- \* the gas tap is open;
- \* the system is at the correct pressure;
- \* the boiler is not blocked.

## 10. TROUBLESHOOTING

0607\_1205

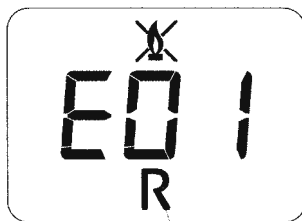

**RESETTABLE  
faults**

Figure 3

Faults are shown on the display with an error code (e.g.: E 01): To **RESET** the boiler, press and hold down "R" for at least 2 seconds. If this fault persists, call the Authorised Service Centre.

**N.B.:** 5 reset attempts can be performed after which the boiler shuts down. To reset again, switch off the boiler for a few seconds.

CODE DISPLAYED	FAULT	CORRECTIVE ACTION
E01	Failed ignition shutdown	Press and hold down "R". for at least 2 seconds. If this fault persists, call the Authorised Service Centre.
E02	Safety thermostat tripped	Press and hold down "R". for at least 2 seconds. If this fault persists, call the Authorised Service Centre.
E03	Flue thermostat/ flue pressure switch tripped	Call the Authorised Service Centre.
E04	Shutdown after 6 consecutive flame losses	Press and hold down "R". for at least 2 seconds. If this fault persists, call the Authorised Service Centre.
E05	Delivery probe failure	Call the Authorised Service Centre.
E06	DHW sensor fault	Call the Authorised Service Centre.
E10	Hydraulic pressure switch block	Check that the pressure in the system is correct; See section 6. If this fault persists, call the Authorised Service Centre.
E25/E26	Probable blocked pump safety trip.	Call the Authorised Service Centre.
E32	Limescale alarm	Call the Authorised Service Centre.
E35	Parasite flame (flamer error)	Press and hold down "R". for at least 2 seconds. If this fault persists, call the Authorised Service Centre.
E96	Switching off due to reductions in the power supply	RESET is automatic. If this fault persists, call the Authorised Service Centre.

**N.B.:** in case of a fault, the display backlighting flashes together with the error code.

## 11. ROUTINE MAINTENANCE INSTRUCTIONS

To keep the boiler efficient and safe, have it checked by the authorised Service Centre at the end of every operating period. Careful servicing ensures economical operation of the system.

Do not clean the outer casing of the appliance with abrasive, aggressive and/or easily flammable cleaners (e.g.: petrol, alcohol, and so on). Always switch off the appliance before cleaning it (see section 7 "Switching off the boiler").

## 12. GENERAL INFORMATION

The following notes and instructions are addressed to fitters to allow them to carry out trouble-free installation. Instructions for lighting and using the boiler are contained in the 'Instructions for Users' section. Moreover, the installation technician must be qualified to install heating appliances.

Additionally, bear in mind the following:

- This boiler can be connected to any type of double- or single-pipe convector plate, radiator or thermoconvector. Design the system sections as usual, though, bearing in mind the available flow-head at the plate, as shown in section 25.
- Do not leave any packaging (plastic bags, polystyrene, etc.) within the reach of children as they are a potential source of danger.
- Initial lighting of the boiler must be carried out by an authorised Service Engineer, as indicated on the attached sheet. Failure to observe the above will render the guarantee null and void.

### ADDITIONAL PUMP WARNING

If an additional pump is used on the heating system, position it on the boiler return circuit. This will allow the correct operation of the water pressure switch.

### WARNING

If the instantaneous (mixed) boiler is connected to a system with solar panels, the maximum temperature of the domestic hot water entering the boiler must not exceed **60°C**.

## 13. INSTRUCTIONS PRIOR TO INSTALLATION

This boiler has been designed to heat water to a temperature lower than boiling point at atmospheric pressure. It must be connected to a central heating system and to a domestic hot water supply system according to its performance and power output.

Do the following before connecting the boiler:

- a) Make sure that the boiler is adjusted to use the type of gas delivered by the gas supply. To do this, check the markings on the packaging and the rating plate on the appliance.
- b) Make sure that the flue terminal draft is appropriate, that the terminal is not obstructed and that no exhaust gases from other appliances are expelled through the same flue duct, unless the latter has been specially designed to collect exhaust gas from more than one appliance, in compliance with current laws and regulations.
- c) Make sure that, if the boiler is connected to existing flue ducts, these have been thoroughly cleaned as residual products of combustion may detach from the walls during operation and obstruct the flow of fumes.

To ensure correct operation and maintain the warranty, observe the following precautions:

#### 1. DHW circuit:

- 1.1. If the water is harder than 20 °F (1 °F = 10 mg calcium carbonate per litre of water), install a polyphosphate dispenser or an equivalent treatment system, compliant with current regulations.
- 1.2. Thoroughly flush the system after installation of the appliance and before use.
- 1.3. The materials used for the domestic hot water circuit of the product comply with Directive 98/83/EC.

#### 2. Heating circuit

##### 2.1. new system

Before proceeding with installation of the boiler, the system must be cleaned and flushed to eliminate residual thread-cutting swarf, solder and any solvents, using suitable proprietary products. To avoid damaging metal, plastic and rubber parts, only use neutral cleaners, i.e. non-acid and non-alkaline. Recommended cleaning products are: SENTINEL X300 or X400 and FERNOX Regenerator for heating circuits. Use these products in strict compliance with the manufacturers' instructions.

##### 2.2. existing plant:

Before installing the boiler, drain the system and clean it to remove sludge and contaminants, using suitable proprietary products as described in section 2.1. To avoid damaging metal, plastic and rubber parts, use only neutral cleaners, i.e. non-acid and non-alkaline such as SENTINEL X100 and FERNOX Protector for heating circuits. Use these products in strict compliance with the manufacturers' instructions. Remember that the presence of foreign bodies in the heating system can adversely affect boiler operation (e.g. overheating and excessive noise of the heat exchanger).

---

**Failure to observe the above will render the guarantee null and void.**

---

## 14. INSTALLING THE BOILER

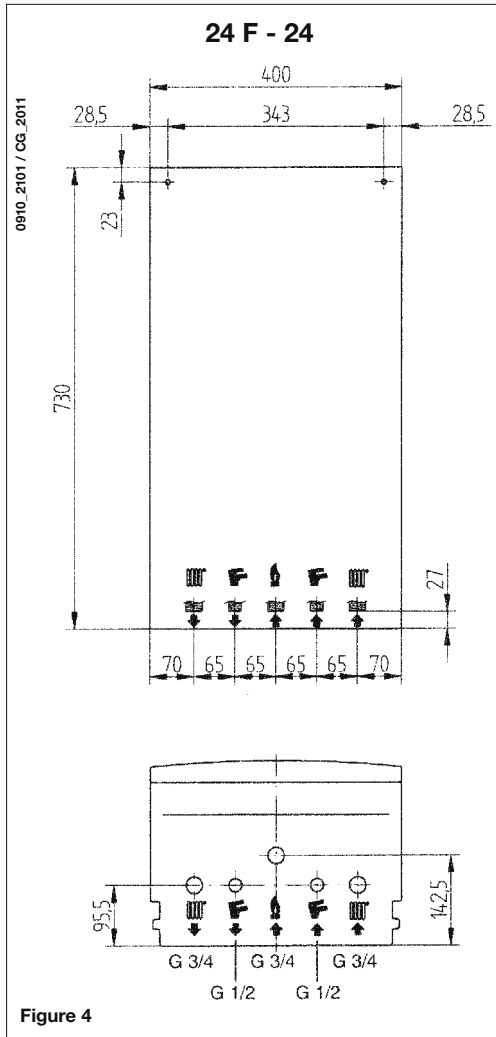

After deciding the exact location of the boiler, fix the template to the wall.

Connect the system to the gas and water inlets present on the lower bar of the template. Fit two G3/4 taps (delivery and return) on the central heating circuit; these taps make it possible to carry out important operations on the system without draining it completely. If you are either installing the boiler on an existing system or replacing one, as well as the above, fit a settling tank under the boiler on the system return line in order to collect any deposits and scale circulating in the system after flushing. After fixing the boiler to the template, connect the flue and air ducts, supplied as accessories, as described in the following sections.

If the model **24** natural draught boiler is installed, connected it to the flue with a metal pipe resistant to normal mechanical stress, heat, products of combustion and relative condensate.

	G"3/4 HEATING DELIVERY
	G"3/4 HEATING RETURN
	G"1/2 DOMESTIC HOT WATER OUTLET
	G"1/2 DOMESTIC COLD WATER INLET
	G"3/4 GAS INLET TO BOILER

## 15. DIMENSIONS OF BOILER

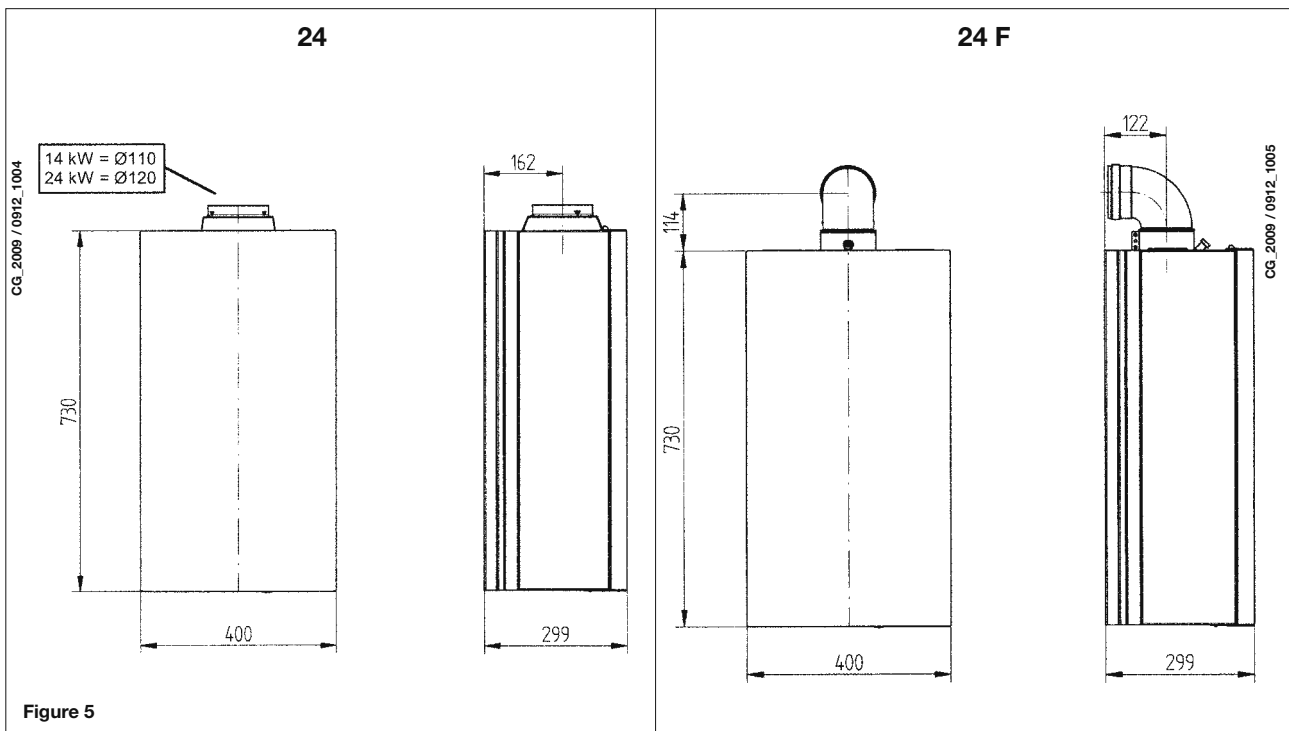



# 16. INSTALLING THE FLUE AND AIR DUCTS

The boiler is easy and flexible to install thanks to the extensive range of available accessories, as described below. The boiler has been designed for connection to a vertical or horizontal coaxial flue-air duct. A splitting kit is also available if separate ducts are required.

**Only accessories supplied by the manufacturer must be used for installation!**

**WARNING : To guarantee more operating insurance it is necessary to assure the flue pipes to the wall using the apposite clamps.**

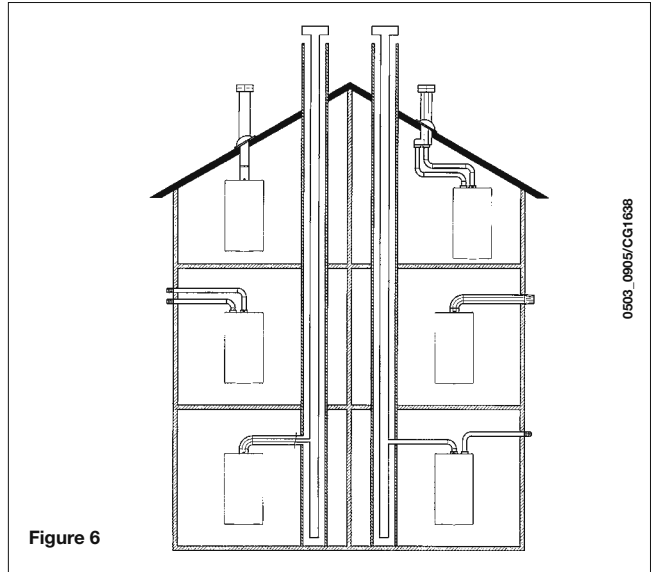

Figure 6

0503\_0905/CC1638

## ... COAXIAL FLUE-AIR DUCT (CONCENTRIC)

This type of duct is used to discharge exhaust fumes and draw combustion air both outside the building and if a LAS flue is fitted.

The 90° coaxial bend allows the boiler to be connected to a flue-air duct in any direction as it can be rotated by 360°. It can also be used as a supplementary bend combined with a coaxial duct or a 45° bend.

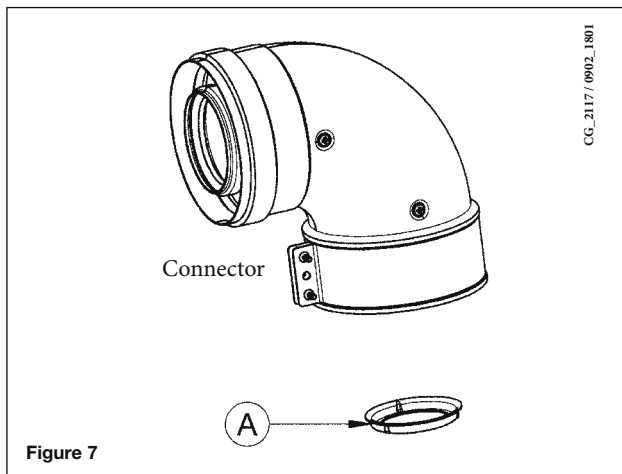

Figure 7

CC\_2117/0902\_1801

If fumes are discharged outside the building, the flue-air duct must protrude at least 18 mm from the wall to allow an aluminium weathering surround to be fitted and sealed to avoid water infiltrations. Make sure there is a minimum upward slope towards the outside of 1 cm per metre of duct.

- a 90° bend reduces total duct length by 1 metre.
- a 45° bend reduces total duct length by 0.5 metres.

**The first 90° bend is not included when calculating the maximum available length.**

Boiler model	Length (m)	Flue RESTRICTOR Ⓐ
24 F	0 ÷ 1	Yes
	1 ÷ 5	No

## 16.1 HORIZONTAL FLUE INSTALLATION OPTIONS

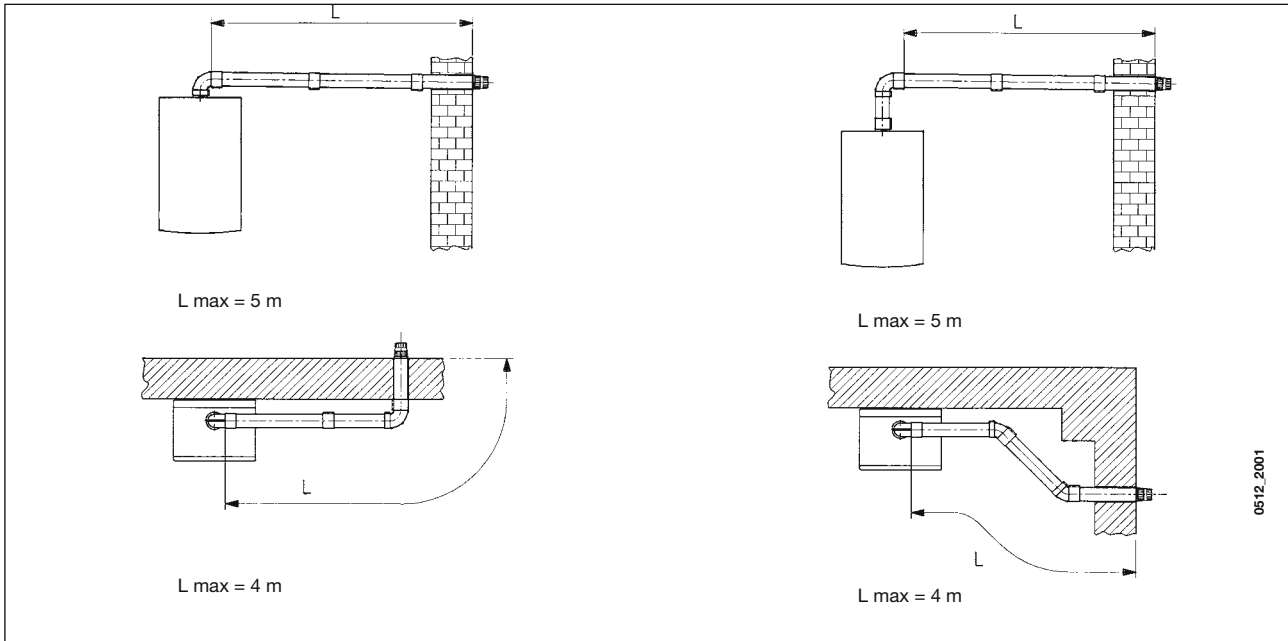

## 16.2 LAS FLUE DUCT INSTALLATION OPTIONS

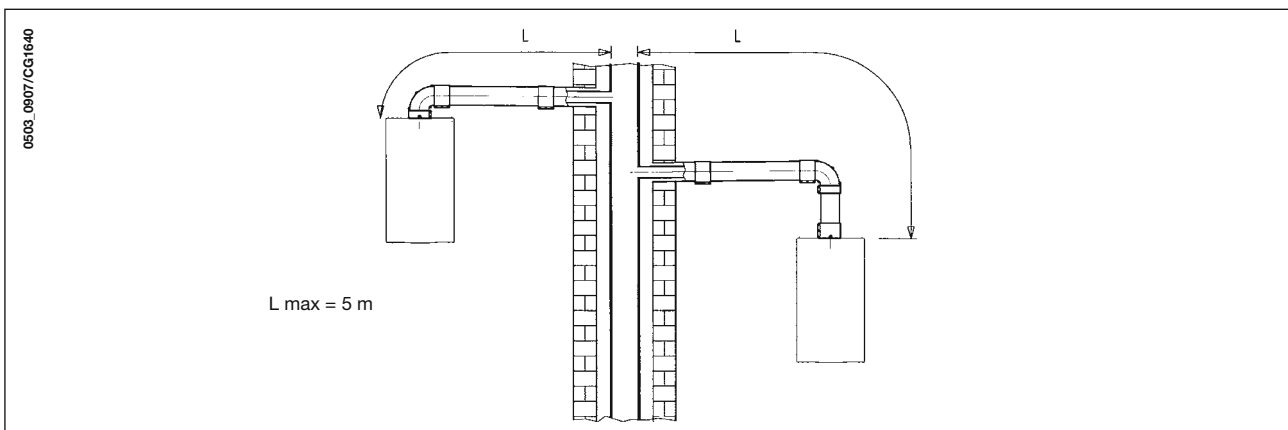

## 16.3 VERTICAL FLUE INSTALLATION OPTIONS

This type of installation can be carried out on either a flat or a pitched roof by fitting a flue terminal and a special weathering surround with sleeve (both available on request).

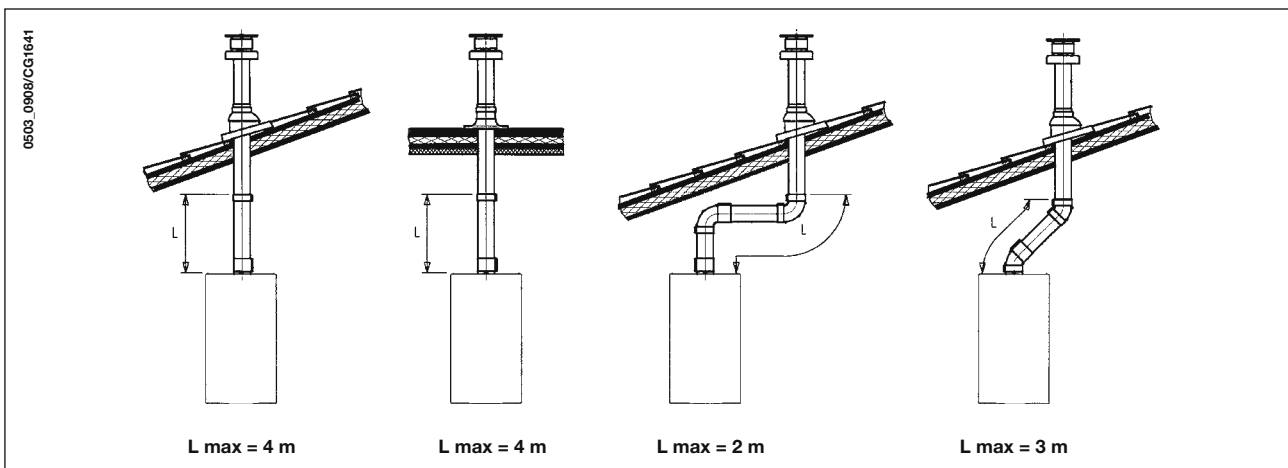

For detailed installation instructions, consult the technical data provided with the accessories.

### ... SEPARATE FLUE AND AIR DUCTS

This type of installation makes it possible to discharge exhaust fumes both outside the building and into single flue ducts. Comburent air can be drawn in at a different location from that of the flue terminal. The splitting kit comprises a flue duct adaptor (100/80) and an air duct adaptor. For the air duct adaptor, fit the screws and seals previously removed from the cap.

Boiler model	(L1+L2)	Position of air regulator	Flue RESTRICTOR Ⓐ	CO <sub>2</sub> %	
				G20	G31
24 F	0 ÷ 4	A	NO	6,4	7,1
	4 ÷ 14	B			
	14 ÷ 23	C			

*The first 90° bend is not included when calculating the maximum available length.*

The 90° bend allows the boiler to be connected to a flue-air duct in any direction as it can be rotated by 360°. It can also be used as a supplementary bend combined with a duct or a 45° bend.

- A 90° bend reduces total duct length by 0.5 metres.
- A 45° bend reduces total duct length by 0.25 metres.

### WARNING

The boiler inlet and outlet ducts (C52) must comply with the following maximum lengths:

- inlet duct: Lmax= 8m
- outlet duct: Lmax= 15m

### Adjusting the air regulator for separate flues

This regulator must be adjusted to optimise combustion efficiency and parameters. After turning the air intake connector, which can be mounted both to the right and the left of the exhaust flue duct, suitably adjust the excess air according to the total length of the combustion exhaust and inlet flue ducts. Turn this regulator counter-clockwise to decrease the excess of comburent air and vice-versa to increase it. To fine tune, use a combustion product analyser to measure the amount of CO<sub>2</sub> in the fumes at maximum heat capacity, and, if a lower value is measured, gradually adjust the air regulator until the amount of CO<sub>2</sub> indicated in the following table is measured. To mount this device correctly, consult the relative instructions.

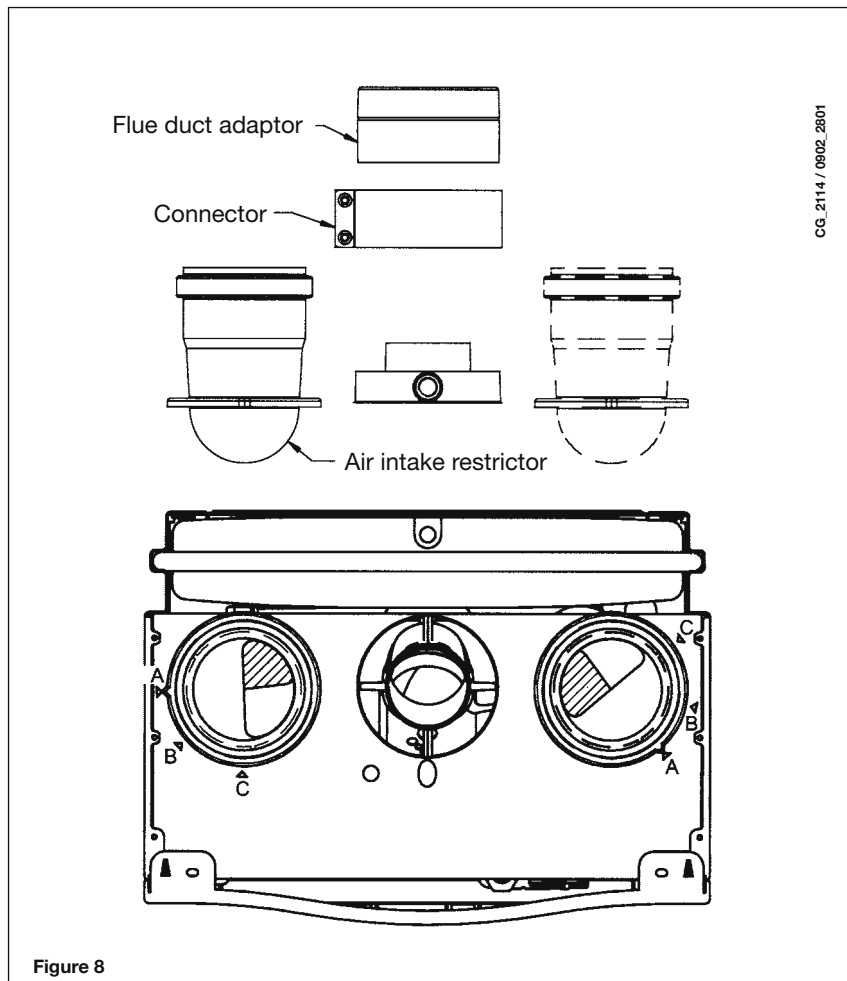
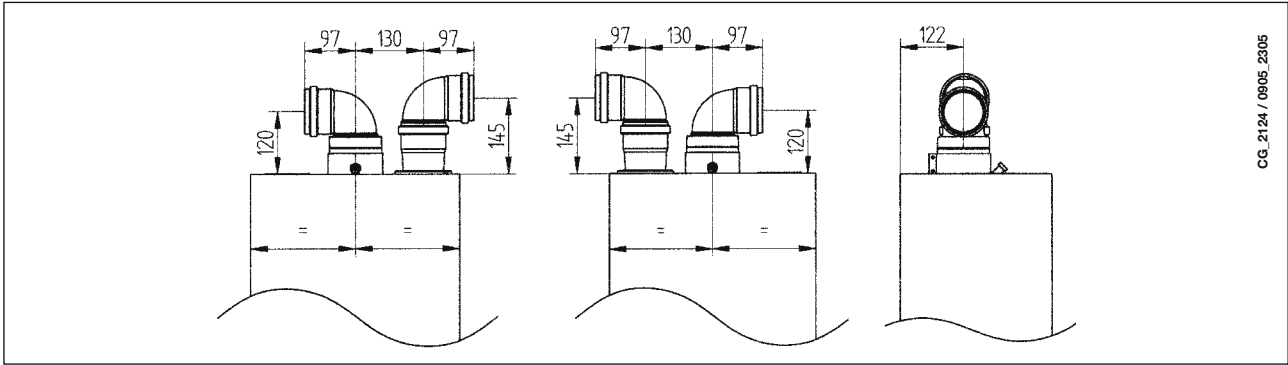

Figure 8

## 16.4 DIMENSIONS OF SEPARATE OUTLETS



CG\_2124 / 0905\_2305

## 16.5 SEPARATE HORIZONTAL FLUE TERMINALS INSTALLATION OPTIONS

**IMPORTANT** - Make sure there is a minimum downward slope towards the outside of 1 cm per metre of duct length. If the condensate collection kit is installed, the discharge duct must slope down towards the boiler.

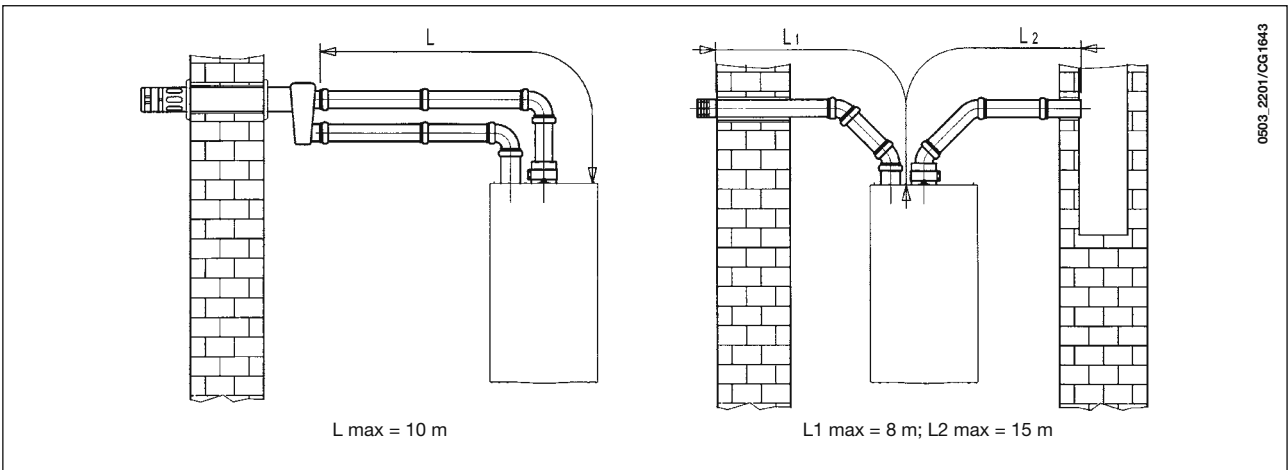

0503\_2201/CG1643

**N.B.:** For the C52 type, do not fit the flue and air duct terminals on opposite walls of the building.

If the discharge duct is longer than 6 metres, install the condensate collection kit, supplied as an accessory, near the boiler.

## 16.6 SEPARATE VERTICAL FLUE INSTALLATION OPTIONS

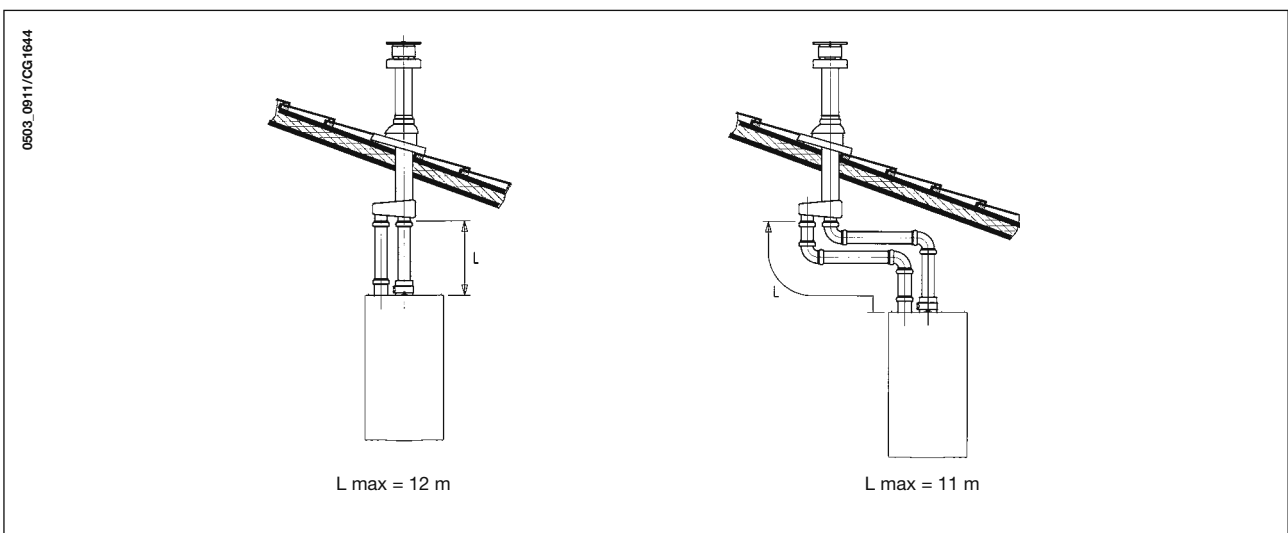

0503\_0911/CG1644

**IMPORTANT:** if fitting a single flue duct, make sure it is adequately insulated (e.g.: with glass wool) wherever the duct passes through building walls. For detailed installation instructions, consult the technical data provided with the accessories.

## 17. ELECTRICAL CONNECTIONS

This machine is only electrically safe if it is correctly connected to an efficient earth system in compliance with current safety regulations.

Connect the boiler to a 230V single-phase earthed power supply using the supplied three-pin cable, observing correct LIVE-NEUTRAL polarity.

**Use a double-pole switch with a contact separation of at least 3 mm.**

When replacing the power supply cable, fit a harmonised HAR H05 VV-F' 3x0.75mm<sup>2</sup> cable with a maximum diameter of 8 mm.

### ...Access to the power supply terminal block

- disconnect the boiler from the mains power supply using the two-pole switch;
- remove the two screws fixing the control panel to the boiler;
- rotate the control panel;
- remove the cover and access the wiring area (figure 9).

The 2A fast-blowing fuse is incorporated in the power supply terminal block (to check and/or replace the fuse, pull out the black fuse carrier).

**IMPORTANT:** respect polarity **L** (LIVE) - **N** (NEUTRAL).

(L) = **Live** (brown)

(N) = **Neutral** (blue)

⊕ = **Earth** (yellow-green)

(1) (2) = **Contact for ambient thermostat**

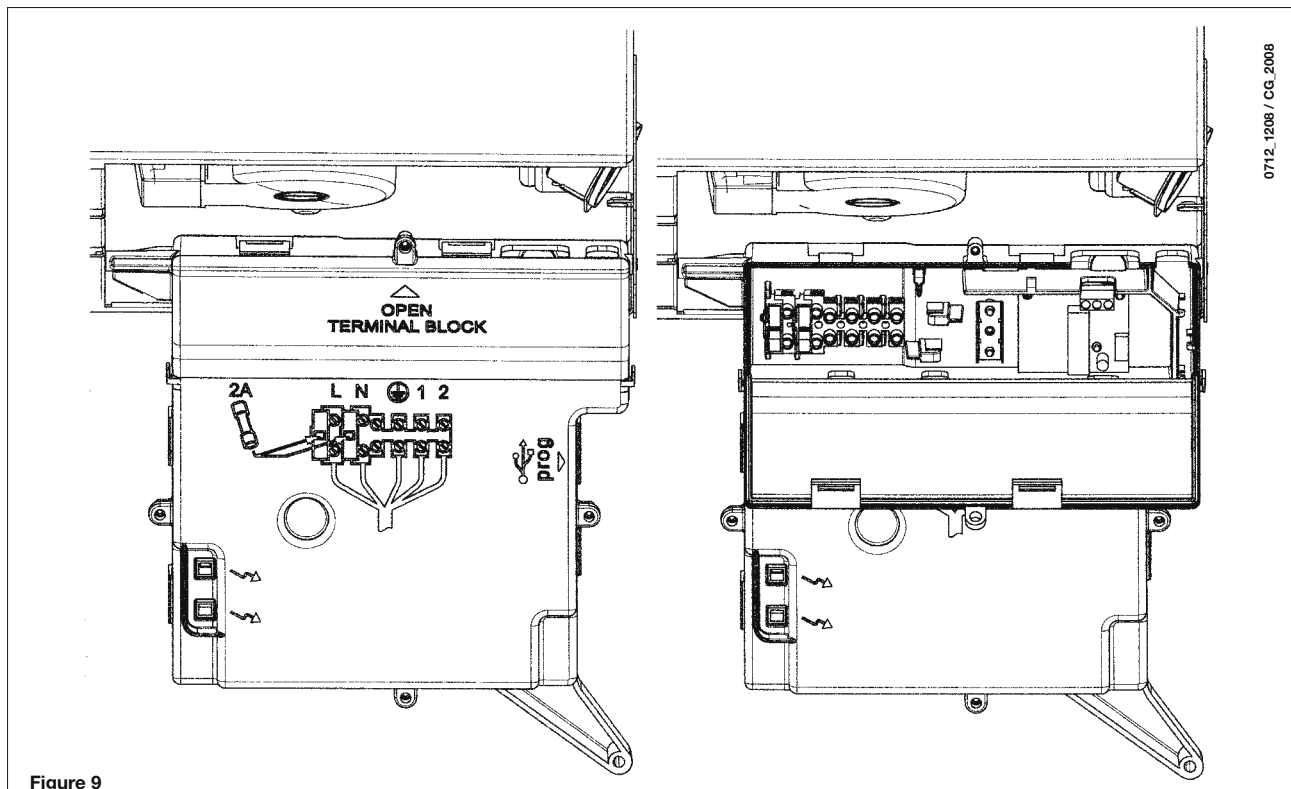

## 18. CONNECTING THE ROOM THERMOSTAT

- access the power supply terminal block (figure 9) as described in the previous section;
- remove the jumper on terminals (1) and (2);
- thread the two-wire cable through the grommet and connect it to these two terminals.

# 19. GAS CONVERSION

The authorised Technical Assistance Service can convert this boiler to natural gas (**G20**) or liquid gas (**G31**).

Carry out the following operations:

- A) replace the main burner nozzles;
- B) Change parameter on electronic board
- C) new max. and min. calibration of the pressure regulator.

### A) Replace the burner injectors

- carefully pull the main burner off its seat;
- replace the main burner injectors making sure to fully tighten them to prevent gas leaks. Injector diameters are specified in table 1.

### B) Change parameters on electronic board

- set parameters **F02**, **F08**, **F09**, **F10**, **F16** according to the gas used, as described in section 21;

### C) Calibrate the pressure regulator (Figure 10)

- connect the positive pressure test point of a differential pressure gauge (possibly water-operated) to the gas valve pressure test point (**Pb**). Only for models with sealed chambers, connect the negative pressure test point of the pressure gauge to a "T" fitting in order to join the boiler adjustment outlet, the gas valve adjustment outlet (**Pc**) and the pressure gauge. (The same measurement can be made by connecting the pressure gauge to the pressure test point (**Pb**) after removing the front panel of the sealed chamber). Measuring burner pressure using methods other than those described could lead to incorrect results as the low pressure created by the fan in the sealed chamber would not be taken into account.

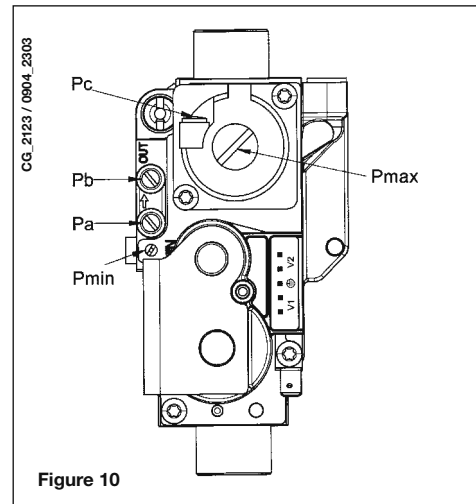

## 19.1 GAS VALVE CALIBRATION FUNCTION

To simplify calibration of the gas valve, the calibration function may be set directly on the boiler control panel as follows:

- a) hold down the buttons + and + together for at least 6 seconds;
- b) after about 6 seconds, the symbols flash;
- c) the display shows, at intervals of one second, "100" and the flow temperature. In this phase, the boiler works at the maximum heating output (100%).
- d) press +/- to immediately set the power of the boiler (100% or 0%);
- e) adjust the "Pmax/Pmin" screw (figure 10) to set the burner pressure value as described in table 1.  
To adjust pressure at maximum power, turn the "Pmax" screw (fig. 10) clockwise to increase or anti-clockwise to decrease pressure at the burner.  
To adjust pressure at minimum power, turn the "Pmin" screw (fig. 10) clockwise to increase or anti-clockwise to decrease pressure at the burner.
- f) press +/- to gradually set the desired power level (interval = 1%).

Press the button to leave the function.

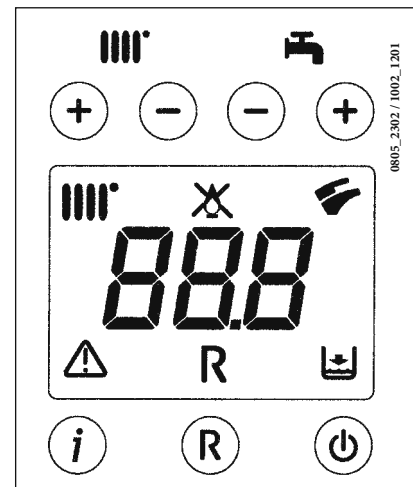







### Note:

The function is automatically deactivated after a period of 15 minutes, at the end of which the electronic board returns to its operating status prior to the activation of the function or prior to reaching the set maximum temperature.

## 19.2 PARAMETERS SETTING

The procedure to access the list of parameters is the following:

- 1) hold down the buttons  and  together for about 6 seconds until the display shows “F01” alternating with the set value;
- 2) press +/-  to scroll through the parameters list;
- 3) to increase or decrease the value of the selected parameter, press buttons +/-  respectively;
- 4) press the  button to save the programming of the set parameters (the display shows for some seconds “MEM”).
- 5) press the  button to leave the programming mode without saving (the display shows for some seconds “ESC”).

### WARNING

For the gas conversion from G20 to G31, modify parameters F02, F08, F09, F10, and F16, as shown in the table in paragraph 21. Attach the additional plate supplied with the transformer, specifying the type of gas and the calibration performed

**Table of burner injectors**

	24		24 F	
	G20	G31	G20	G31
gas type				
diameter of nozzles (mm)	1,18	0,74	1,35	0,85
Burner pressure (mbar*) <b>REDUCED HEAT OUTPUT</b>	2,2	6,3	2,2	5,4
Burner pressure (mbar*) <b>RATED HEAT OUTPUT</b>	13,1	35,3	11,3	28,5
N° nozzles	13		11	

\* 1 mbar = 10,197 mm H<sub>2</sub>O

**Table 1**

Consumption 15°C-1013 mbar	24		24 F	
	G20	G31	G20	G31
<b>Rated power</b>	2,78 m <sup>3</sup> /h	2,04 kg/h	2,73 m <sup>3</sup> /h	2,00 kg/h
<b>Reduced power</b>	1,12 m <sup>3</sup> /h	0,82 kg/h	1,12 m <sup>3</sup> /h	0,82 kg/h
<b>p.c.i.</b>	34,02 MJ/m <sup>3</sup>	46,34 MJ/kg	34,02 MJ/m <sup>3</sup>	46,34 MJ/kg

**Table 2**

## 20. VISUALISATION OF PARAMETERS ON THE DISPLAY ("INFO" FUNCTION)

Press "i" for at least 5 seconds to visualise certain boiler information on the display on the front panel of the boiler.

**N.B.:** when the "INFO" function is enabled, the message "A00", alternating with the boiler delivery temperature, is shown on the display (figure 12):

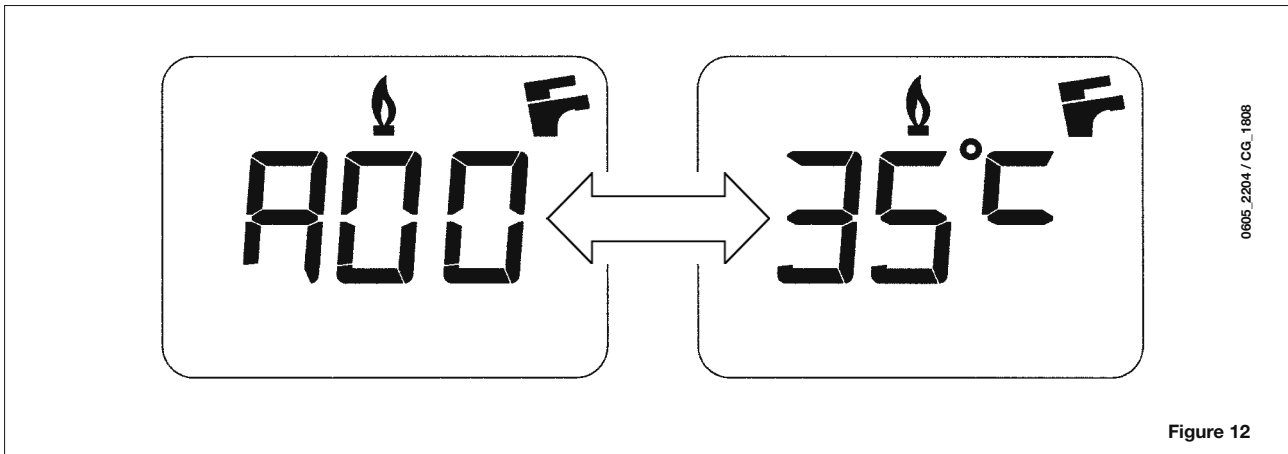



- Press buttons  (+/-) to display the following information:

- A00:** current DHW temperature (°C);
- A01:** current external temperature (°C) (with external probe connected);
- A02:** current (%) at modulator (100% = 230 mA NATURAL GAS - 100% = 310 mA LPG);
- A03:** power range (%) (MAX R);
- A04:** heating setpoint temperature (°C);
- A05:** current heating delivery temperature (°C);
- A06:** DHW temperature setpoint value (°C);
- A07:** flame signal % value (0-100%);
- A08:** Not used;
- A09:** last error that occurred in the boiler;





- This function remains active for 3 minutes. It is possible to interrupt the "INFO" function in advance by holding down the button ( ) for at least 5 seconds, or turning off the power to the boiler.



## 21. PARAMETERS SETTING

To set the boiler parameters press the (- ) and (- ) buttons together for at least 6 seconds. When the function is active, the letters "F01" will appear on the display, alternating with the value of the parameter shown.

### Changing the parameters

- Press the (+/- ) buttons to scroll through the parameters;
- Press the (+/- ) buttons to change each parameter value;
- Press the button () to save changes, the display shows "MEM";
- Press the button () to leave the function without saving, the display shows "ESC";

	Description of parameters	Factory settings	
		24 F	24
F01	Type of boiler 10 = sealed chamber - 20 = atmospheric chamber	10	20
F02	Gas used 00 = NATURAL (METHANE) - 01 = LPG	00 o 01	
F03	Hydraulic system	00	
F04	Setting programmable relays (See SERVICE instructions) 00 = no associated function	00	
F06	Maximum temperature setpoint setting (°C) 00 = 76°C (Switching off the burner at 80°C) 01 = 45°C	00	
F07	Configuration DHW priority input	02	
F08	Max heating power GAS G31 (3P)   GAS G20 (2H) 24F = 100   24F = 80 24 = 100   24 = 90	80	90
F09	Max DHW power GAS G31 (3P)   GAS G20 (2H) 24F = 100   24F = 80 24 = 100   24 = 90	80	90
F10	Min heating power GAS G31 (3P)   GAS G20 (2H) 24F = 00   24F = 20 24 = 00   24 = 10	20	10
F11	Waiting time in heating before a new ignition (00-10 minutes) - 00=10 seconds	03	
F12	Diagnostics (See SERVICE Instructions)	--	
F13	Type of exchanger 00 = 270 mm 01 = 225 mm	01	00
F14	Testing the correct position of the DHW probe 00 = Disable 01 = Enable	01	00
F15	Factory setting	01	00
F16	Min DHW power GAS G31 (3P)   GAS G20 (2H) 24F = 00   24F = 20 24 = 00   24 = 10	20	10

## 22. ADJUSTMENT AND SAFETY DEVICES

This boiler has been designed in full compliance with European reference standards and, in particular, it is fitted with the following:

- **Air pressure switch (model 24 F)**

This device only allows the burner to ignite if the exhaust flue duct is in perfect working order.

In the event of one or more of the following faults:

- flue terminal obstructed
- venturi tubes obstructed
- fan blocked
- venturi tube connection - pressure switch tripped

the boiler remains on standby and error code E03 is displayed (see table in section 10).

- **Fumes thermostat (model 24)**

This device, the sensor of which is positioned to the left of the fumes hood, interrupts the flow of gas to the main burner if the flue is obstructed and/or there is no draught.

In these conditions the boiler shuts down and displays error code E03 (section 10).

After eliminating the problem, it is possible to reignite by holding down the **(R)** button for at least 2 seconds.

---

It is forbidden to disable this safety device

---

- **Safety thermostat**

Thanks to a sensor placed on the heating delivery line, the thermostat interrupts the flow of gas to the burner if the water in the primary circuit overheats. In these conditions, the boiler is blocked and only after the fault has been eliminated can it be ignited again by pressing **(R)** button for at least 2 seconds.

---

It is forbidden to disable this safety device

---

- **Flame ionisation detector**

The flame sensing electrode, located on the right-hand side of the burner, guarantees safety of operation in case of gas failure or incomplete ignition of the burner.

In these conditions, the boiler is blocked after 3 ignition attempts.

Press the **(R)**, for at least 2 seconds to re-establish normal operating conditions.

- **Hydraulic pressure switch**

This device allows the main burner to be ignited only if system pressure is higher than 0.5 bars.

- **Pump overrun for heating circuit**

The electronically-controlled pump post-circulation function lasts 180 seconds and is enabled, in the heating mode, if the ambient thermostat causes the burner to go out.

- **Pump overrun for DHW circuit**

The electronically-controlled pump post-circulation function lasts 30 seconds and is enabled, in the DHW mode, if the probe causes the burner to go out.

- **Frost protection device (heating)**

The electronic boiler management system includes a "frost protection" function for the heating system which, when delivery temperature falls below 5°C, operates the burner until a delivery temperature of 30°C is reached. This function is enabled when the boiler is switched on, the gas supply is open and the system is correctly pressurised.

- **Water not circulating in primary circuit (pump probably blocked)**

If there is insufficient or no water circulating in the primary circuit, the boiler blocks and the error code E25 is shown on the display (section 10).

- **Anti-block pump function**

If no heat demand is received for 24 consecutive hours, in the heating mode, the pump will automatically start and operate for 10 seconds.

This function is operative when the boiler is powered.

- **Hydraulic safety valve (heating circuit)**

This device is set to 3 bar and is used for the heating circuit.

---

Connect the safety valve to a drain tap. Do not use it to drain the heating circuit.

---

**N.B.:** domestic hot water is guaranteed even if the NTC sensor develops a fault. In this case, temperature is controlled by the delivery sensor.

## 23. POSITIONING THE IGNITION AND FLAME-SENSING ELECTRODE

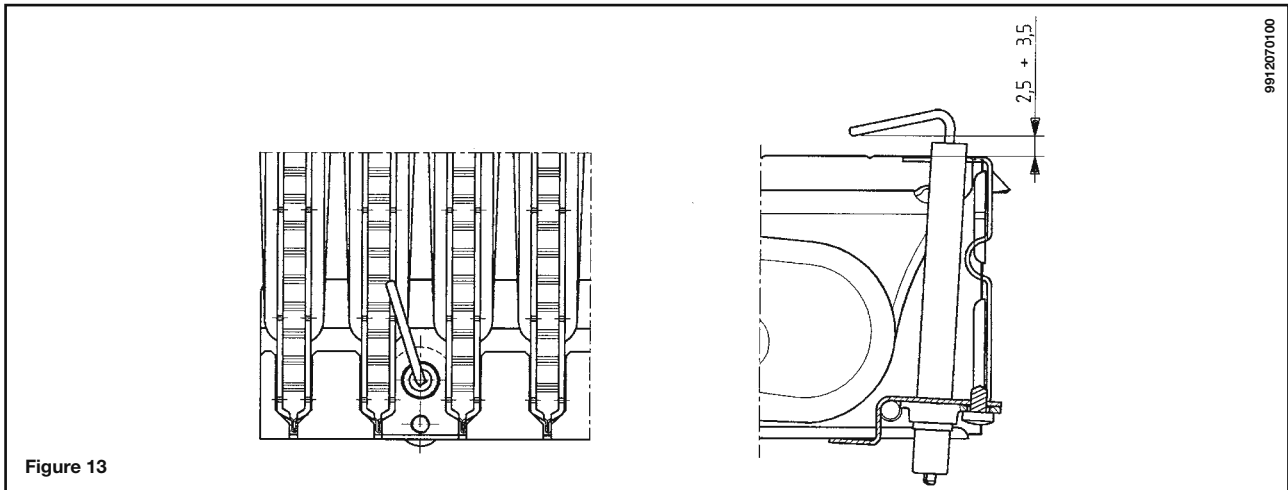

Figure 13

## 24. CHECKING COMBUSTION PARAMETERS

To measure combustion efficiency and the toxicity of the products of combustion, the boiler is fitted with two dedicated test points.

One test point is connected to the exhaust duct and is used to measure combustion efficiency and the toxicity of the products of combustion.

The other is connected to the air intake duct and is used to check for the presence of any products of combustion circulating in installations with co-axial flues.

The following parameters can be measured using the test point connected to the exhaust duct:

- temperature of the products of combustion;
- concentration of oxygen (O<sub>2</sub>) or, alternatively, carbon dioxide (CO<sub>2</sub>);
- concentration of carbon monoxide (CO).

The temperature of the comburent air must be measured on the test point located on the air intake flue by inserting the measurement sensor by about 3 cm.

**N.B.:** to regulate the rated power, see chapter 19 (C1)

For natural draught boiler models, a hole must be made in the exhaust duct at a distance from the boiler equal to twice the internal diameter of the flue. The following parameters can be measured inside this hole:

- temperature of the products of combustion;
- concentration of oxygen (O<sub>2</sub>)
- concentration of carbon monoxide (CO).

The temperature of the combustion air must be measured close to the point where the air enters the boiler.

The hole, which must be made by the person in charge of the system during commissioning, must be sealed so as to ensure that the exhaust duct is airtight during normal operation.

## 25. PUMP CAPACITY/ HEAD

A high static head pump, suitable for installation on any type of single- or double-pipe heating system, is used. The automatic air valve incorporated in the pump allows quick venting of the heating system.

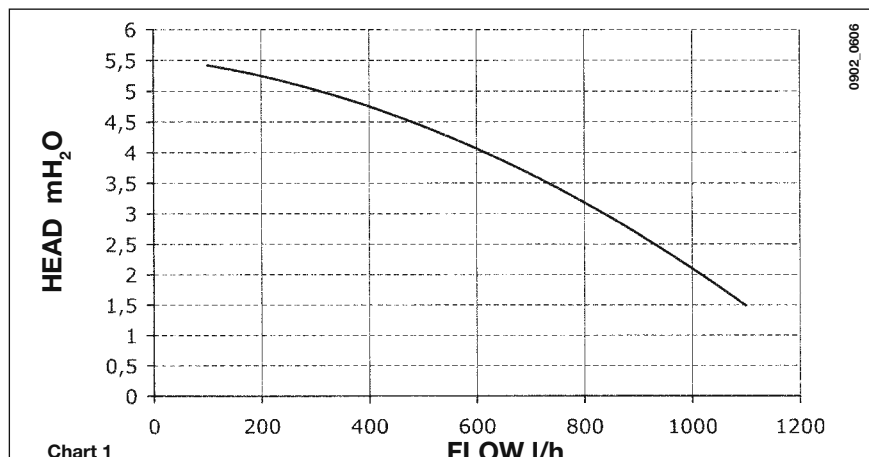

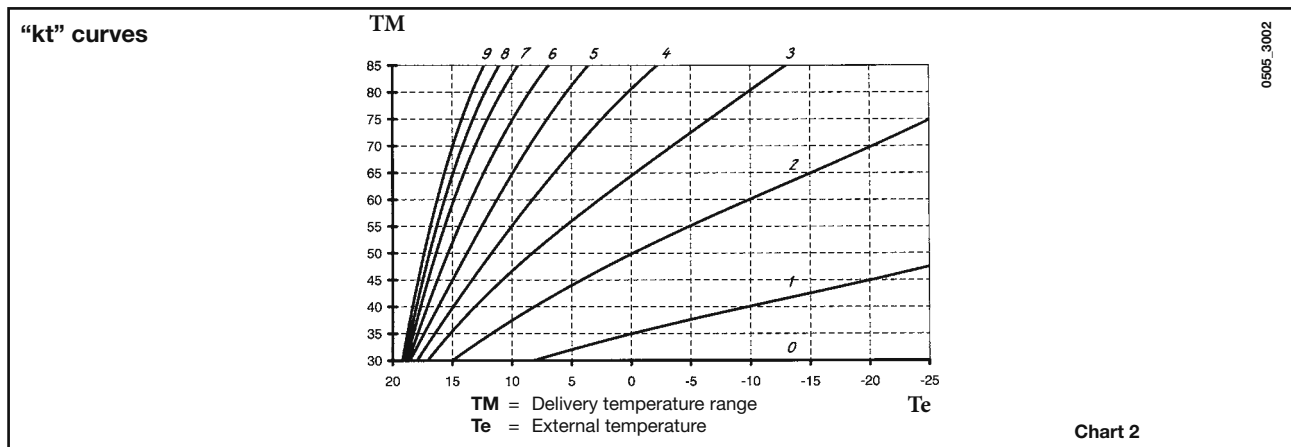

Chart 1

## 26. CONNECTING THE EXTERNAL PROBE

The wiring harness leaving the control board includes two RED wires fitted with faston covers. Connect the external probe to these two wires.

With the external probe connected it is possible to change the curve "kt" (Graph 1) by means of the +/-  buttons.



## 27. NOTES FOR INSTALLATIONS WITH SEPARATE OUTLETS

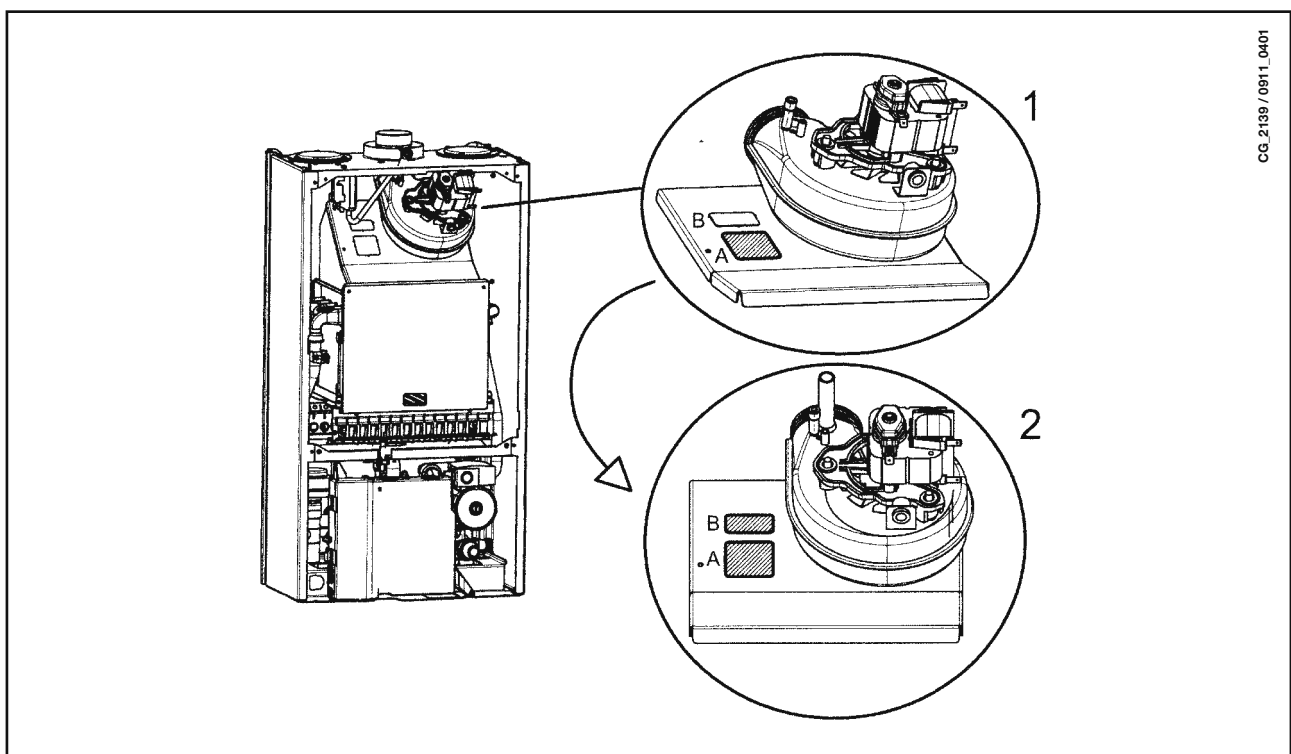

In special cases, installations with separate outlets can generate vibrations that may cause the fumes pressure switch to trip (fault E03 on the boiler display).

To solve this problem, two slots closed with pre-punched holes (Ref. **A** and **B**) have been prepared on the fumes outlet. These can be easily removed by the Qualified Technical Assistance Service without having to remove the outlet.

Remove knock-out **A** (Detail 1) and check the appliance works correctly.  
If not, remove knock-out **B** (Detail 2) as well.

## 28. ANNUAL SERVICING

To optimise boiler efficiency, carry out the following annual controls:

- check the appearance and air-tightness of the gaskets of the gas and combustion circuits;
- check the state and correct position of the ignition and flame-sensing electrodes;
- check the state of the burner and make sure it is firmly fixed;
- check for any impurities inside the combustion chamber.  
Use a vacuum cleaner to do this;
- check the gas valve is correctly calibrated;
- check the pressure of the heating system;
- check the pressure of the expansion vessel;
- check the fan works correctly;
- make sure the flue and air ducts are unobstructed;

---

### WARNINGS

**Before commencing any maintenance operations, make sure the boiler is disconnected from the power supply. Afterwards, move the knobs and/or operating parameters of the boiler to their original positions.**

---

# 29. FUNCTIONAL CIRCUIT DIAGRAM

24 F

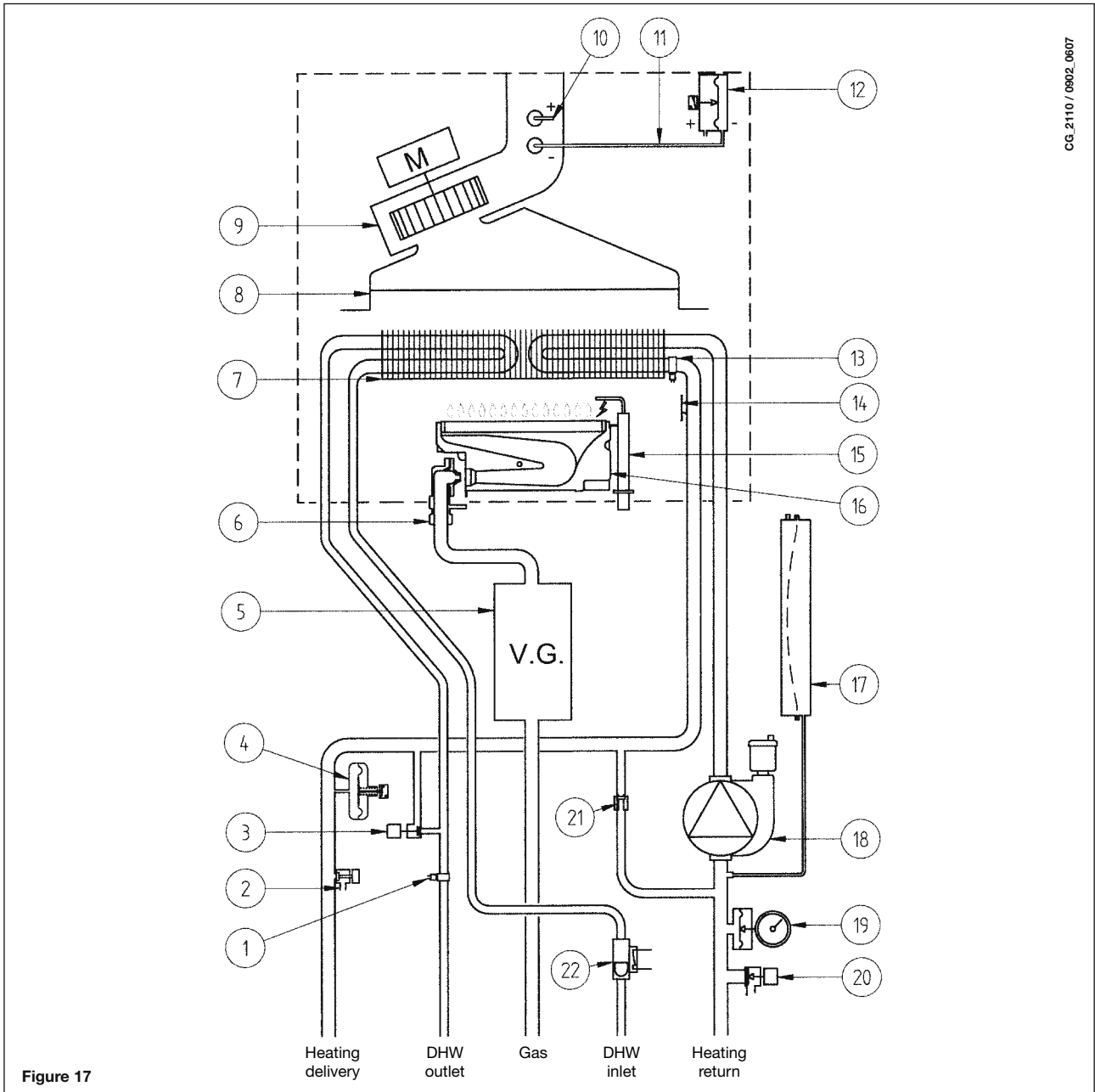

Figure 17

## Legend:

- |    |                               |    |                                      |
|----|-------------------------------|----|--------------------------------------|
| 1  | NTC domestic hot water sensor | 12 | Air pressure switch                  |
| 2  | Boiler drain tap              | 13 | Central heating NTC sensor           |
| 3  | Boiler filling tap            | 14 | Safety thermostat                    |
| 4  | Water pressure switch         | 15 | Ignition / flame detection electrode |
| 5  | Gas valve                     | 16 | Burner                               |
| 6  | Gas train with injectors      | 17 | Expansion vessel                     |
| 7  | Water-fumes exchanger         | 18 | Pump and air separator               |
| 8  | Fumes conveyor                | 19 | Pressure gauge                       |
| 9  | Fan                           | 20 | Safety valve                         |
| 10 | Positive pressure point       | 21 | Automatic by-pass                    |
| 11 | Negative pressure point       | 22 | DHW priority sensor                  |

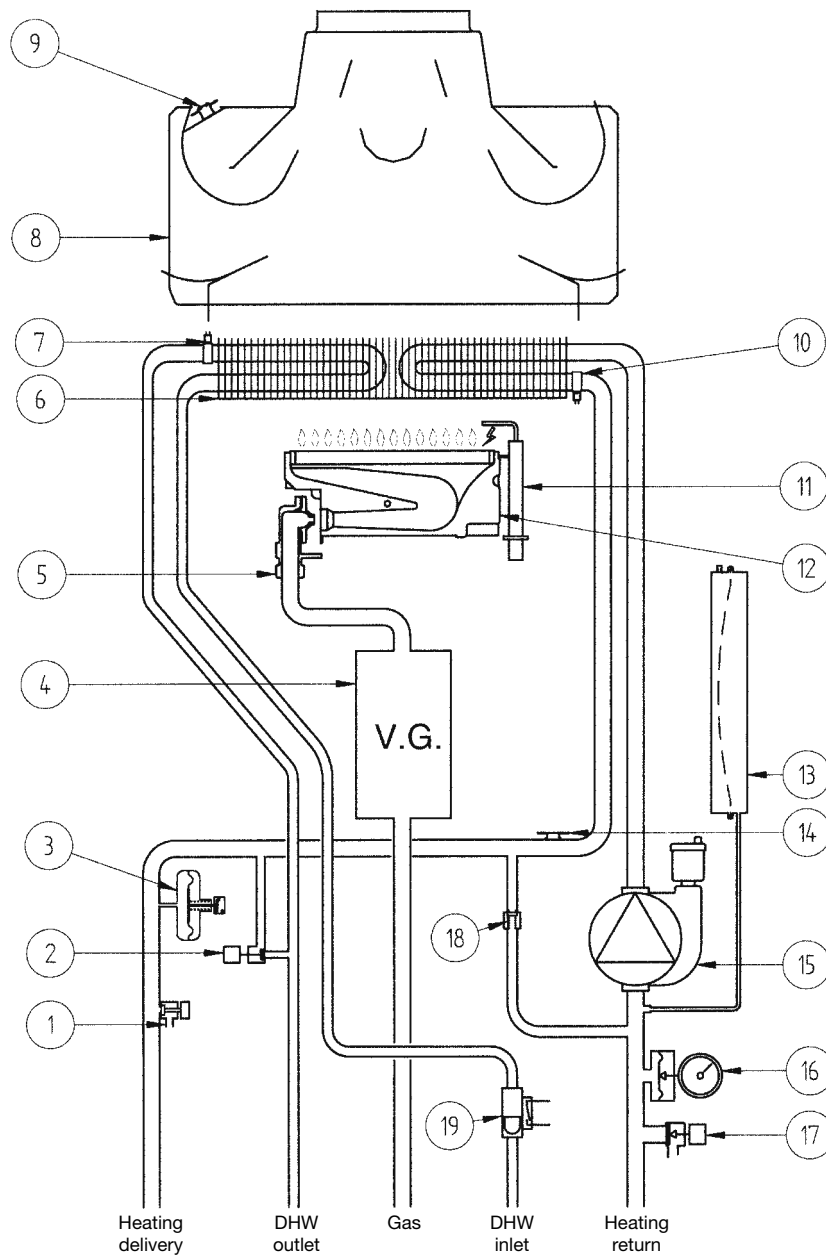

Figure 18

**Legend:**

- |                                 |   |
|---------------------------------|---|
| 1 Boiler drain tap              | 10 Central heating NTC sensor           |
| 2 Boiler filling tap            | 11 Safety thermostat                    |
| 3 Water pressure switch         | 12 Ignition / flame detection electrode |
| 4 Gas valve                     | 13 Burner                               |
| 5 Gas train with injectors      | 14 Expansion vessel                     |
| 6 Water-fumes exchanger         | 15 Pump and air separator               |
| 7 NTC domestic hot water sensor | 16 Pressure gauge                       |
| 8 Fumes conveyor                | 17 Safety valve                         |
| 9 Fumes thermostat              | 18 Automatic by-pass                    |
|                                 | 19 DHW priority sensor                  |

# 30. WIRING DIAGRAM

24 F

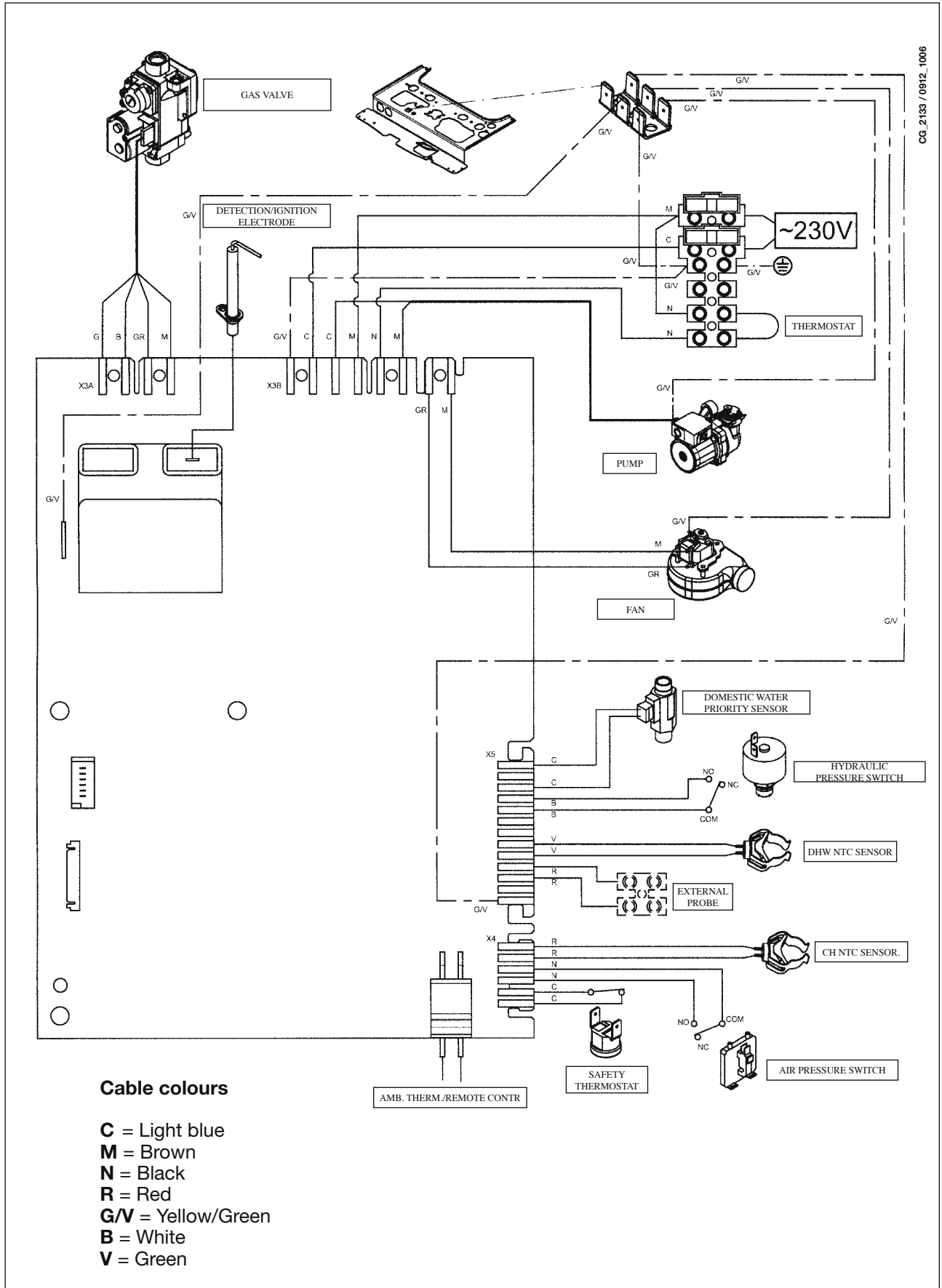

CG\_2133 / 0912\_1006



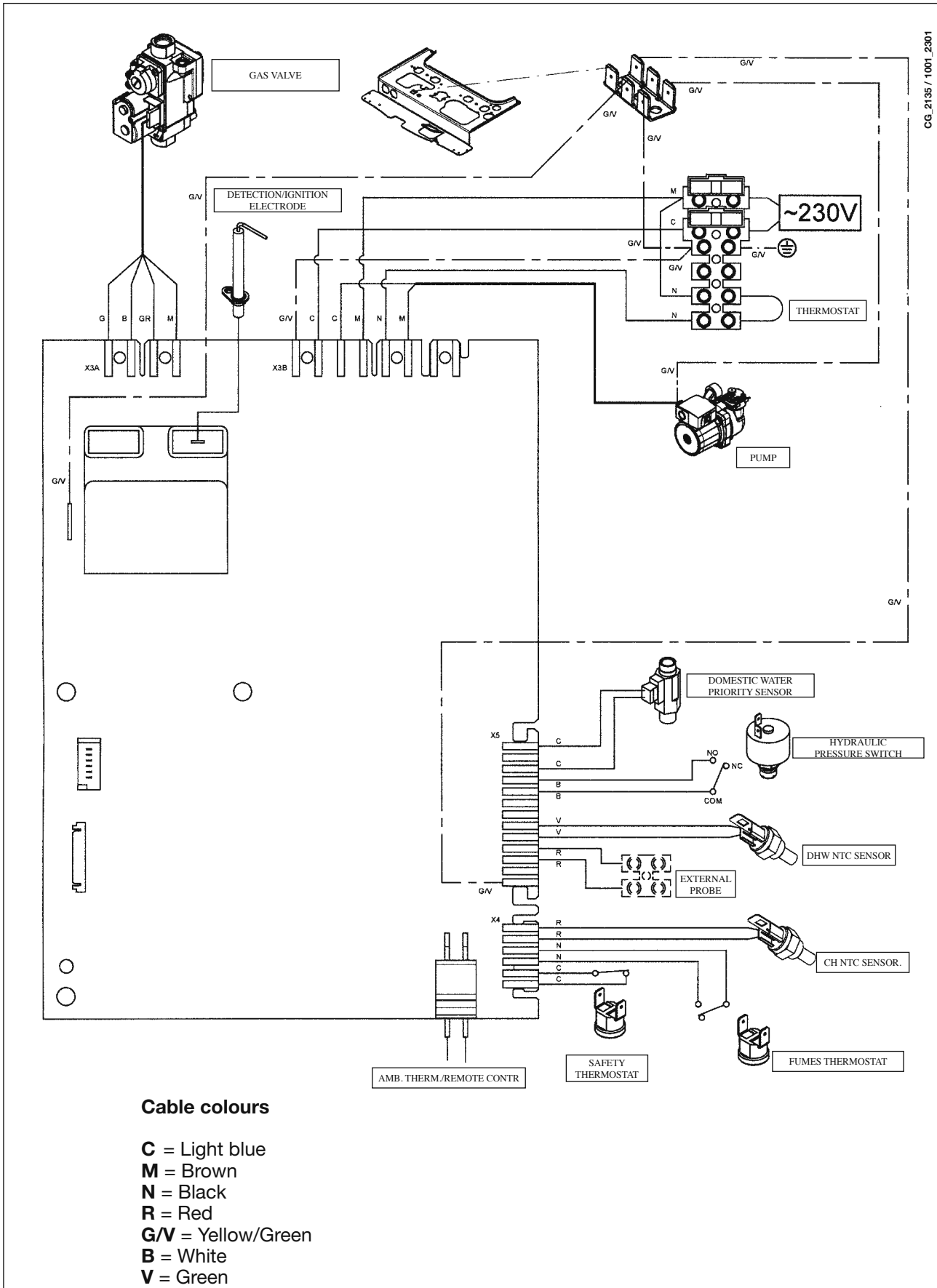

CG\_2135 / 1001\_2301

## 31. TECHNICAL DATA

<b>Model QUASAR D</b>			<b>24 F</b>	<b>24</b>
<b>Category</b>			<b>II<sub>2H3P</sub></b>	<b>II<sub>2H3P</sub></b>
Rated heat input	kW		25,8	26,3
Reduced heat input	kW		10,6	10,6
Rated heat output	kW		24	24
	kcal/h		20.600	20.600
Reduced heat output	kW		9,3	9,3
	kcal/h		8.000	8.000
Efficiency according to Directive 92/42/EEC	–		★★★	★★
Max. pressure in central heating system	bar		3	3
Capacity of expansion vessel	l		6	6
Pressure of expansion vessel	bar		1	1
Max. pressure in DHW system	bar		8	8
Minimum dynamic pressure in DHW system	bar		0,15	0,15
Minimum DHW output	l/min		2,0	2,0
DHW output at $\Delta T=25\text{ }^{\circ}\text{C}$	l/min		13,7	13,7
DHW output at $\Delta T=35\text{ }^{\circ}\text{C}$	l/min		9,8	9,8
Specific output (*)	l/min		11	11
Temperature range in heating system	$^{\circ}\text{C}$		30/76	30/76
Temperature range in DHW system	$^{\circ}\text{C}$		35/55	35/55
Type	–	C12-C32-C42-C52-C82-B22		B <sub>11BS</sub>
Diameter of concentric flue duct	mm		60	-
Diameter of concentric air duct	mm		100	-
Diameter of 2-pipe flue duct	mm		80	-
Diameter of 2-pipe air duct	mm		80	-
Diameter of flue duct	mm		-	120
Max. mass flow of fumes	kg/s		0,016	0,021
Min. mass flow of fumes	kg/s		0,016	0,018
Max. temperature of fumes	$^{\circ}\text{C}$		149	120
Min. temperature of fumes	$^{\circ}\text{C}$		119	86
NOx class	–		3	3
Type of gas	–		G20	G20
	–		G31	G31
Natural gas supply pressure	mbar		20	20
Propane gas supply pressure	mbar		37	37
Power supply voltage	V		230	230
Input frequency	Hz		50	50
Rated electrical input	W		130	80
Net weight	kg		31	29
Dimensions	height	mm	730	730
	width	mm	400	400
	depth	mm	299	299
Protection against humidity and water penetration (**)			IP X5D	IP X5D

(\*) according to EN 625

(\*\*) according to EN 60529

As WESTEN constantly strives to improve its products, it reserves the right to modify the information contained in this document at any time and without prior notice. This document is issued purely for the sake of information and should not be considered as a contract with third parties.